

# Running Bond

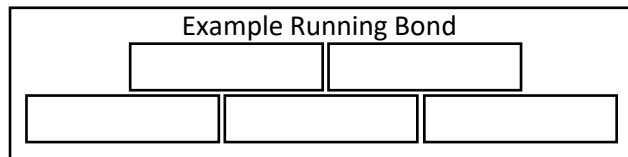

Project: \_\_\_\_\_

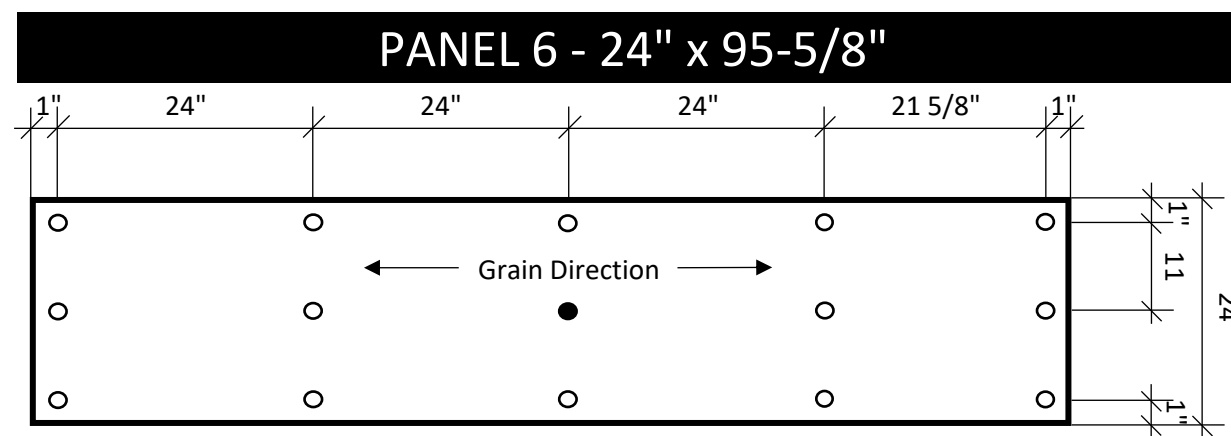
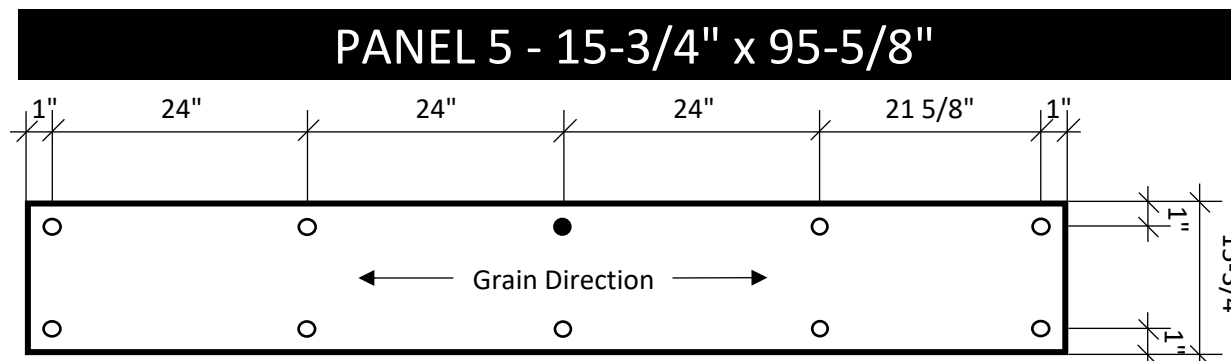
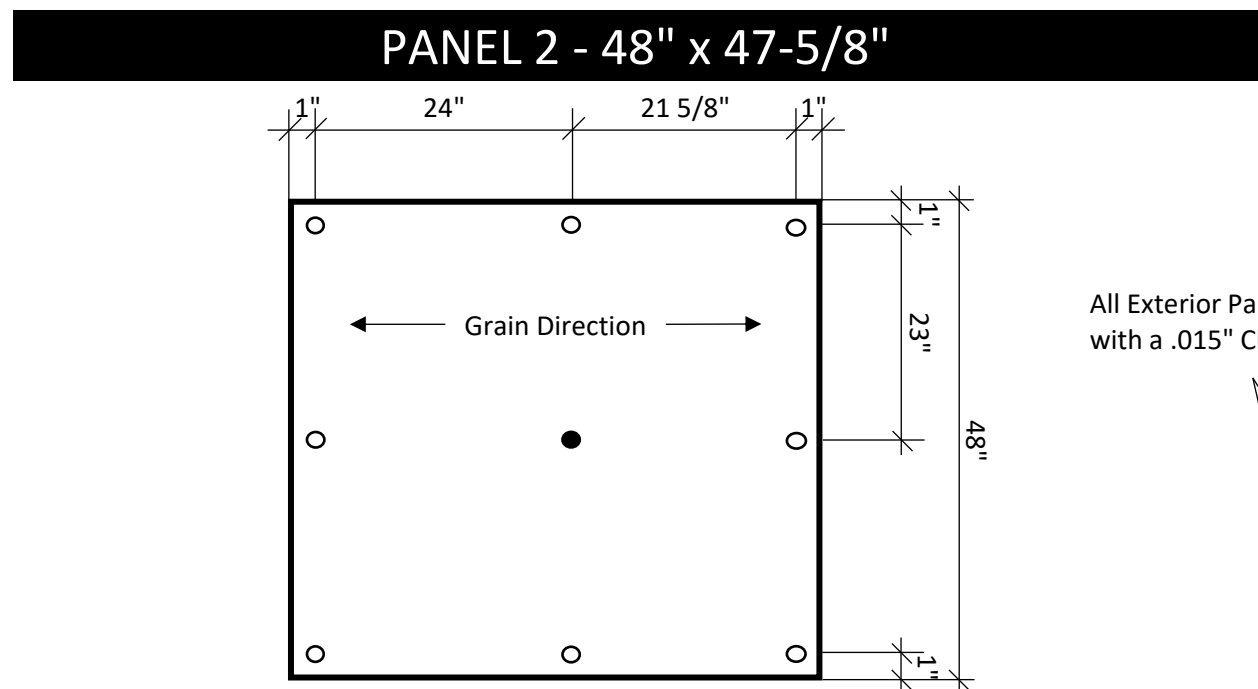
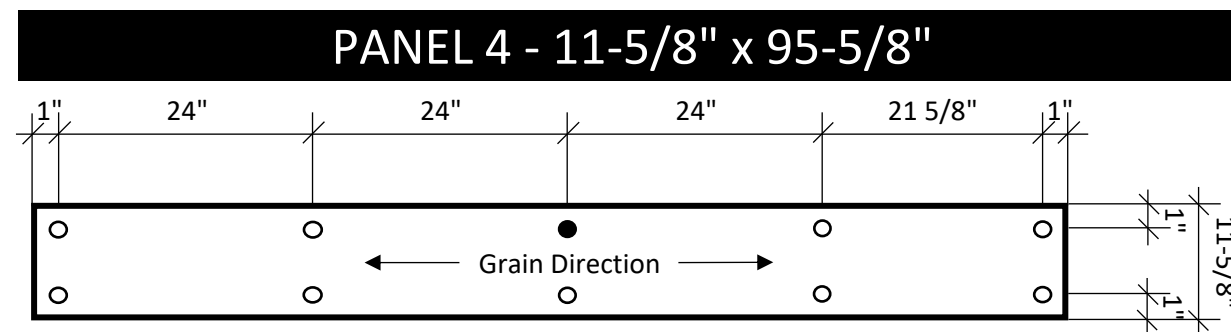
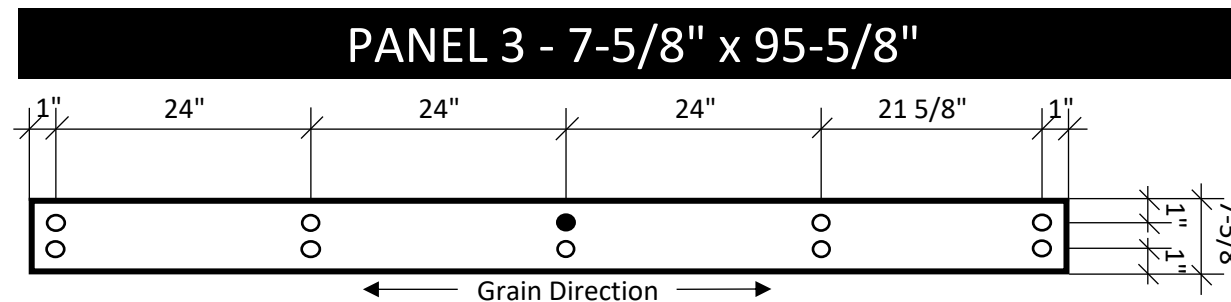
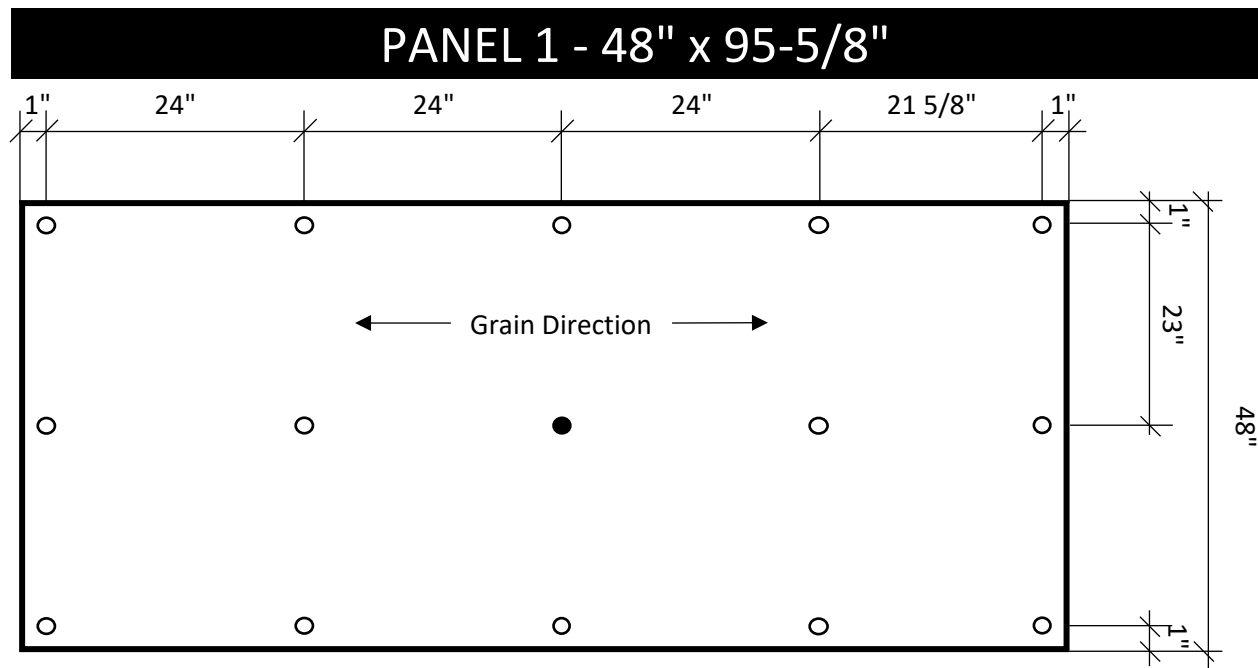

All Exterior Panels Arrive with a .015" Chamfer Edge

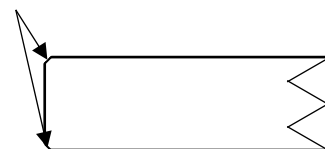

**DRILLING KEY FOR TORX FASTENERS:**

- = FIXED POINT 7/32" HOLE
- = FLOATING POINT 5/16" HOLE

Panel: \_\_\_\_\_

Customer Signature: \_\_\_\_\_

No Alterations are Accepted